

Dorsal Root Ganglion (DRG) Versatile Stimulator Prototype Developed for Use in Locomotion Recovery Early Clinical Trials*

Konstantina Kolovou-Kouri, Sadaf Soloukey, *Member, IEEE*, Frank J.P.M. Huygen, Biswadji S. Harhangi, Wouter A. Serdijn, *Fellow, IEEE* and Vasiliki Giagka, *Member, IEEE*

Abstract — This paper presents the development of a Dorsal Root Ganglion (DRG) stimulator system intended for use in early clinical trials for motor recovery after Spinal Cord Injury (SCI). It allows for independent control of multisite/multilevel bilateral (on both sides of the spinal cord) stimulation, it can supply a high output current of 25.4mA, and has the ability to program pulse sequences similar to actual locomotion patterns. These characteristics ultimately provide the required versatility for examining the effects of DRG stimulation on locomotion recovery, which is lacking in currently available commercial systems. The device is created using commercially available components to make the design reproducible by other research labs and to facilitate the critical approval procedure for use in a clinical research environment. Throughout the design phase, essential considerations regarding the safety of the participating patient, as well as of the medical personnel involved, were taken into account and these are analyzed and demonstrated in this paper. Such considerations are very rarely discussed in scientific literature and the authors consider that, apart from the design of the system itself, this discussion is a critical contribution of this paper.

I INTRODUCTION

In the event of Spinal Cord Injury (SCI), the neuronal pathways between the brain and the rest of the body are damaged. As a consequence, many physiological processes such as motor control, sensory feedback or autonomic functioning are (partially) disrupted, leading to a loss of functional independence [1] or an overall loss in quality of life [2]. No clinical treatment is available for complete recovery after an SCI, however, there are attempts at recovering locomotion [3]. In an experimental setting, neuromodulation of the spinal pathways below the site of injury seems to be one of the most promising approaches [3]. Epidural Spinal Cord Stimulation (eSCS) has been one of the most common applications and offers the ability to reinstate voluntary motor control in patients with (motor complete) SCI, with or without concomitant rehabilitation [4] – [6].

Recently, a relatively new target for neuromodulation in SCI has surfaced. By targeting the Dorsal Root Ganglion (DRG), researchers have shown the ability to evoke strong, long-lasting muscle responses leading to knee extension [7] (Fig. 1A-C). Compared to eSCS, DRG stimulation – which has already been established for chronic pain treatment [8] – has the potential to target relevant muscle groups in a more

selective manner [7, 9, 10]. In order to be truly applicable in the context of SCI, this single DRG-level proof-of-principle needs to be expanded to a multi-level approach, targeting multiple levels of DRG leads in a sequence that would mimic a physiological, locomotive pattern. However, currently available commercial devices are tailored to the context of chronic pain treatment and do not allow for this type of fast, multi-channel stimulation.

The current paper focuses on the development of a multi-channel external pulse generator prototype system (EPG), designed to target up to 16 channels independently, to further explore the effects of multi-level DRG stimulation on motor recovery after SCI during early clinical trials. The prototype system comprises the external stimulating hardware, interfacing with 8 implantable multi-electrode leads, and a suitable user interface. It is created by utilizing commercially available components, to ensure reproducibility by other research labs and to expedite the required approval procedure necessary to be obtained prior to inclusion in early clinical trials. Along with the presentation of the developed prototype, this work is addressing the patient safety considerations that arise from such system integration. Such considerations, despite being common practice for commercially developed systems, are very rarely reported in scientific literature. The authors consider this discussion to be one of the main contributions of this paper and hope that it will facilitate actual application in a clinical research environment for this and future experimental prototypes developed in academic laboratories.

The paper is organized as follows: Section II summarizes the results of the first clinical trials on motor recovery after SCI through DRG stimulation and emphasizes the need for the development of a new tailored system. Section III provides an overview of the proposed system (hardware and software), demonstrating the safety considerations for its use in clinical trials. Section IV discusses how these considerations are crucial when developing systems that are useable in such a context, with Section V concluding the paper and highlighting its contribution.

II PRIOR ART AND CURRENT NEEDS ON DRG STIMULATION

In their 2020 paper [7], Soloukey *et al.* for the first time demonstrate how L4-level DRG stimulation is able to evoke

*Research supported by Fraunhofer Attract excellence fellowship, Fraunhofer-Gesellschaft, DE.

K. Kolovou-Kouri, W.A. Serdijn and V. Giagka are with the Bioelectronics Section, Dept. of Microelectronics, Faculty of Electrical Engineering, Mathematics and Computer Science, Delft University of Technology, the Netherlands (Corresponding author e-mail: K.KolovouKouri@tudelft.nl).

K. Kolovou-Kouri and V. Giagka are also with the Technologies for Bioelectronics Group, Dept. of System Integration and Interconnection Technologies, Fraunhofer Institute for Reliability and Microintegration IZM.

S. Soloukey^a, B.S. Harhangi^b, Frank J.P.M. Huygen^c and W.A. Serdijn^d are with the Dept. of Neurosurgery^{ab}, Dept. of Neuroscience^{ad}, and Dept. of Anesthesiology^c, Erasmus MC, Rotterdam, the Netherlands.

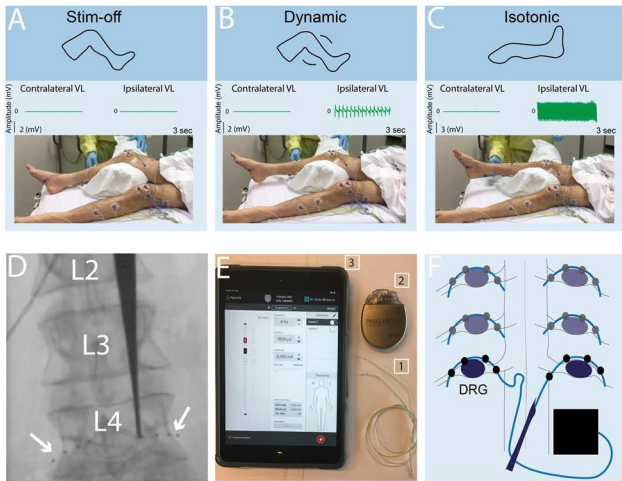

Fig. 1. Overview of the status-quo of the DRG as a novel target for neuromodulation. Fig. 1A-C demonstrate how DRG stimulation could evoke dynamic and isotonic muscle response ipsilateral to the side of stimulation. Fig. 1D shows an intra-operative X-ray image of the bilateral DRG lead placement. Fig. 1E gives an overview of the Abbott® DRG stimulation device (Proclaim™ DRG). Fig. 1F provides an example of multi-level DRG stimulation and lead placement, which would require a new type of multichannel stimulator (back box).

reproducible muscle response in the upper leg muscles of five patients with motor complete SCI. These responses lead to a strong, long-lasting extension of the leg in the knee joint. The authors describe how DRG stimulation could evoke both dynamic (high-amplitude stimulation, Fig. 1B) as well as isotonic (high-amplitude, high-frequency stimulation, Fig. 1C) muscle responses, here displayed using the EMG responses of the Vastus Lateralis (VL) muscle as an example. For this study, the DRG leads (part of the Abbott® Proclaim™ DRG neurostimulator system) were placed percutaneously under X-ray guidance (Fig. 1D) on the bilateral L4-level DRGs. Each lead consists of 4 electrode points that are individually addressable. The complete commercially available Abbott® DRG stimulation platform employed for this study, including the Implantable Pulse Generator (IPG), providing a connection to a maximum of 4 DRG leads, and the clinician interface on a tablet is illustrated in Fig. 1E.

To achieve locomotion-like stimulation, several stimulator characteristics need to be considered, in parallel to systems tailored for pre-clinical eSCS studies [11] – [14]. While the stimulator by Abbott provides a physical connection to a maximum of 4 leads, it cannot address them simultaneously, but in a time-multiplexed manner. However, multiple DRGs will need to be accessed bilaterally and at once, to recruit the right muscle groups at the right moment in the locomotion cycle. For the purpose of multilevel DRG stimulation, no such pulse generator is currently commercially available. Fast switching times between the stimulating leads and the possibility of interleaved stimulation across multiple leads to allow for left-right alteration or agonist-antagonist recruitment, can also enhance locomotion-like stimulation. More complex stimulation patterns (e.g. ramping the current up/down instead of simply turning it on/off, delays in the pulse sequence, skipping a pulse) can increase the flexibility in programming the pulse sequence and generating a more realistic locomotion pattern. Conventional EPGs have a maximum current output of 6 mA. However, based on

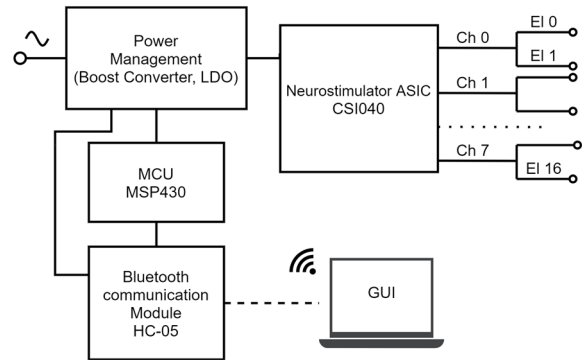

Fig. 2. Block diagram of the stimulator system proposed for this study. An MCU programs the stimulation parameters, a Bluetooth module communicates with any external components (i.e., a GUI on a local PC). 8 independent stimulation channels are able to flexibly address a total of 16 electrodes concurrently.

previous studies [7], this range can fall short in terms of motor recruitment. Having a larger current output range (within safety constraints) may facilitate stronger muscle contraction.

III PROPOSED SYSTEM ARCHITECTURE, RESULTS AND SAFETY CONSIDERATIONS

A. DRG multichannel stimulator prototype architecture

A block diagram of the complete system is presented in Fig. 2. The prototype stimulator is a non-CE marked multichannel device, which can drive multiple leads concurrently to facilitate faster, sequential stimulation. To ensure reproducibility by other research labs, only commercially available components were used.

The core element of the stimulator prototype is its highly programmable current sink/source ASIC (Application Specific Integrated Circuit), CSI040, developed by Cirtec Medical [15]. It features 16 independent, 7-bit-programmable current outputs. The CSI040 ASIC is mounted on the CSI062 board, a demonstration board for the CSI040 ASIC, also developed by Cirtec Medical [16]. The device provides electrical pulses that will be applied to the DRG through the CE-marked DRG leads from Abbott® (Proclaim™ DRG). Each DRG lead is equipped with 4 electrodes, and given the 16 outputs of the stimulator, a maximum of 8 leads in total can be stimulated simultaneously when using 2 of the 4 electrodes of each lead (which can be easily expanded to all 4 with an added demultiplexer). The leads are connected to the prototype through properly fitted connectors, constructed in-house using the A22041-001 connectors from Omnetics.

A user is able to select the parameters for each stimulation channel, such as pulse width, pulse frequency, stimulation on/off times, stimulation current, and amplitude ramping, all of which are fully programmable, via a Graphical User Interface (GUI) on a local computer. These parameters are wirelessly communicated via a Bluetooth module (HC-05 by ITEad Studio) to the Microcontroller Unit (MCU) (MSP430I2041TRHBT, Texas Instruments), which, in turn, controls the remaining of the system and updates the stimulator outputs. The system can provide a high output current up to 25.4 mA and a high output voltage up to 18V, with the current per electrode being software-limited to max. 6mA. The stimulation pulse width ranges between 10μs and 1280μs and the frequency between 0.15Hz and 7kHz.

TABLE I. COMPARISON OF STIMULATOR DEVICES

	This work	[7] ^a	[17]	[5]	[18]
Goal	Restoring locomotion	Restoring locomotion	Somatosensory neuroprostheses	Restoring locomotion	Pain relief
Stimulation target ^b	DRG	DRG	DRG	SC	SC
Preclinical vs. clinical	Under review for clinical	Clinical	Preclinical	Clinical	Clinical
No of independently program. channels in total/ for bilateral control	16/8	1/4	1/1	1/1	32
No of electrode points in total/ independently addressable	32/16	16/16	32/32	16/16	32
Levels of bilateral stimulation ^d	4	2	1	1	2
Stimulation parameters (current amplitude, frequency, pulse width)	0 – 25.4mA^c	0 – 6mA	0 – 1.5mA	16mA	25.5mA
	0.15Hz – 7kHz	4 – 80Hz	0 – 1kHz	2 – 1200Hz	0 – 1.2kHz
	10 – 1280µs	40 – 1000µs	100µs – 50ms	60 – 1000µs	20 – 1000µs

a. The system used in [5] is originally intended for pain relief, however it is the only system in the literature used for restoring locomotion when stimulating the DRG.

b. All systems use Current-Controlled Stimulation (constant current pulses).

c. The stimulator is capable of delivering 25.4mA in total for a parallel electrode configuration, if required, however a delivery of max. 6mA per electrode will be limited by the software of the device.

d. For use in DRG stimulation, based on the number of leads that can be connected to the IPG.

Table I summarizes these characteristics of the system in comparison with other existing experimental setups aiming at locomotion recovery or targeting the DRG. The number of independently programmable channels refers to the option of programming the stimulation parameters individually for every channel. Out of a total of 16, the current configuration allows for control of 8 channels, to be used in order to stimulate the DRG bilaterally (on both sides of the SC) on 4 spinal cord levels, using 2 channels (2 leads) for each level. The number of independently addressable electrode points refers to the possibility of setting each electrode as anode, cathode or neutral (no current flow), without changing the physical connections to the leads. Out of a total of 32, 16 electrode points are currently independently addressable, which can be expanded to 32 when adding a demultiplexer to the topology. These characteristics allow for the versatility that is required to study the effects of multi-site DRG stimulation for locomotion recovery.

B. Safety Considerations

The safety requirements that need to be met differ greatly for preclinical (animal) and clinical (human) research, which often dictates the need for clinical research to rely on previously tested and approved components. Clinical research focuses to a large extent on the safety, comfort, and well-being of the patients participating in the studies. In the following paragraphs we discuss how to take into account the above requirements when designing a system for clinical research.

To begin with, we consider the type of clinical studies the device will be used in, in terms of duration and means of application. In this case, the envisioned studies will be performed in-hospital and for a short period of time, as part of a larger chronic trial. Following this decision, the hardware items that will be used in the studies need to be identified. For out application these are the CE-marked DRG leads and the developed stimulator prototype. As the DRG leads are already

CE-marked, all further safety considerations and device testing are conducted with regards to the stimulator prototype and the system as a whole, grouped into risk assessments regarding (1) risk of infection and (2) the electrical functionality of the device, for the safety of both the patient and the medical personnel involved in the study.

(1) Infection-related risks: It is important to ensure that no non-sterile parts are in direct contact with the patient to eliminate risks of infection or injury. In our proposed prototype, the only parts that are in direct contact with neuronal tissue are the already CE-marked DRG leads, which are kept sterile. The stimulator is in physical contact with the stimulating DRG lead only through an externalized, non-sterile lead extension. Before a chronic lead and device implantation, the externalized extension will be removed.

(2) Electrical functionality related risks: The safety of the patient as well as of the medical personnel must be ensured in case of a single-fault failure. To establish this, parameters regarding powering the device, protection from any direct current (DC) leakage, and safe operation are considered.

In this implementation, the device is powered from the mains for a constant and reliable supply, while a medical AC-DC adapter (MDS-030AAC05, Delta Electronics) is chosen for a proper protection and isolation of the device. The adapter is suitable for type BF (body float) applications, namely for applications that have conductive contact with the patient, since it exhibits a low touch current, meaning that any current leakage paths that might be in contact with the patient or operator will not surpass a specific threshold. A double MOPP (Means Of Patient Protection) isolation provides a double layer of insulation to protect the patient from any electrically charged equipment that might come in contact with the device, and an IP22 ingress protection rating protects the adapter against insertion of fingers and maintains its safety even when exposed to dripping water.

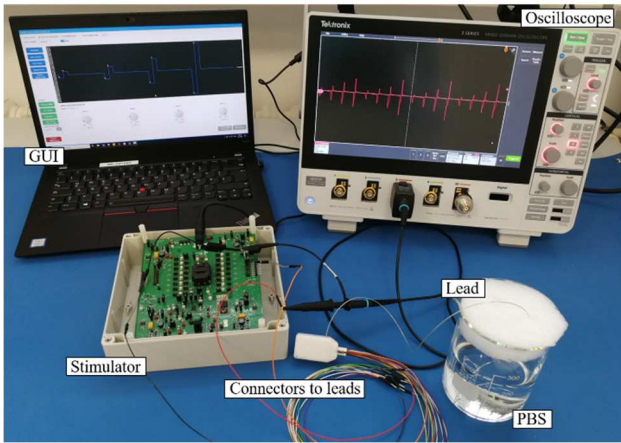

Fig. 3. Measurement setup used for the safety evaluation of the stimulator prototype. The DRG leads are connected to the stimulator on one end and submerged in a PBS solution on the other end. The stimulating sequences are programmed through a GUI on a laptop and the output signals are measured with an oscilloscope.

In the event of a device fault, any DC that might leak through the electrode can cause great damage to the neural tissue. To prevent this, medical-grade coupling capacitors (tantalum capacitors, $10\mu\text{F}$) are placed in series with the stimulating electrodes, for both the anodic and the cathodic path of the stimulating current. These capacitors are specifically designed for use in non-critical medical applications, exhibiting DC leakage levels that are significantly lower than commercial solid tantalum capacitors.

The device is enclosed in a polymer casing, guarding its electronic components from the outside environment and providing electrical isolation, between the device and its users. Any openings on the casing, made to allow for a connection to the stimulating leads or the powering adapter, are secured through rubber cable grommets to reinforce the hole through which the cables pass and to protect the cable from any sharp edges and vibrations. Furthermore, the rubber grommets prevent sliding of the cable due to friction.

To verify its safe use, the stimulator prototype underwent a safety evaluation. For that purpose, the device was tested using the Abbott® DRG leads submerged in a Phosphate-buffered saline (PBS) solution (0.14 M NaCl , 2.7 mM KCl , $10\text{ mM phosphate buffer}$, with a pH-value of 7.4 ± 0.05) to emulate the environment of the inner body, as well as with a chicken breast phantom model. The measurements were conducted with the 3-Series Mixed Domain Oscilloscope (MDO34) by Tektronix®. The setup for the measurements can be seen in Fig. 3. Fig. 4 illustrates the various stimulation waveforms and patterns that the proposed system can deliver.

To demonstrate the proper and safe function of the stimulator, the voltage between the anode and the cathode of the system was observed (shown in Fig. 5) [11]. The voltage drop of 1.1V at the beginning of the stimulus pulse is a product of the resistive behavior of the electrolyte, while the capacitive nature of the stimulating electrodes results in an almost linear change of the measured voltage during both phases of the biphasic pulse. The potential difference between points 1 and 2 of Fig. 5 should be in the range of a specific potential, known as the water window, outside which

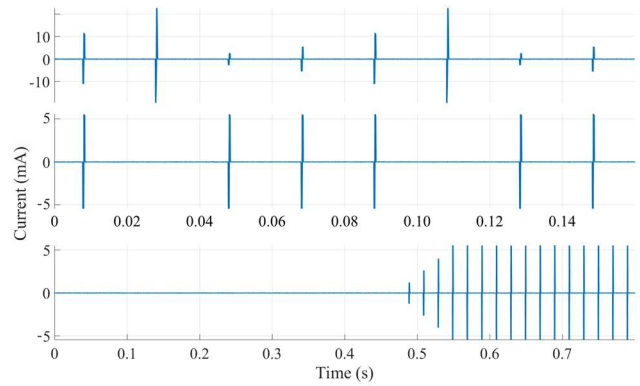

Fig. 4. Delivered current, as measured over a 511Ω resistor, when delivering $3/6/12/25\text{mA}$ to the load (top graph), when skipping a pulse in the stimulation sequence (middle graph), when ramping up the stimulation sequence (bottom graph), all at a 48Hz frequency.

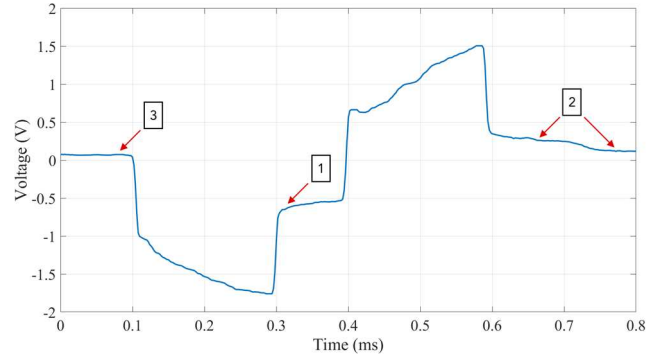

Fig. 5. Measured voltage between the anode and the cathode of the system, when delivering 6mA to the load at a 48Hz frequency.

electrolysis occurs. This potential is relative to the electrode material, in this case Platinum Iridium (PtIr). Here, it is measured at -0.6V at point 1 and 0.25V at point 2 (falling to 0.12V after only $100\mu\text{s}$), which falls inside the suggested water window for Pt and PtIr electrodes, at $\phi > -830\text{mV}$ and $\phi < 1230\text{mV}$ respectively [19]. Finally, the interpulse potential (point 3 on Fig. 5), an effect which builds up after a number of biphasic pulses, should remain close to zero, so that it will not allow for any harmful electrochemical reactions. Here it is measured at 70mV , which we expect is low enough as to not harm the stimulated tissue [20].

Another parameter that is considered regarding the safety of the stimulator, is the stimulation parameter k as described by the Shannon equation, a dimensionless parameter expressing the relation between the charge density (charge per surface area) and the charge per phase of a stimulation pulse. This parameter is more representative for macroelectrodes, but tends to over or under estimate the safety limits for microelectrodes, as the ones used in this system [21]. In any case, the maximum charge density to be delivered at 6mA , $D = 30.5\mu\text{C}/\text{cm}^2$, falls in the accepted levels for FDA approved devices [21].

To determine if there is any tissue overheating at the stimulating leads, a thermal analysis was conducted with the E60 Thermal Imaging Camera of Flir. The temperature at the leads inserted in the chicken breast phantom model, was compared before and after 30 minutes of continuous stimulation, at the highest possible current level of 25.4mA , a

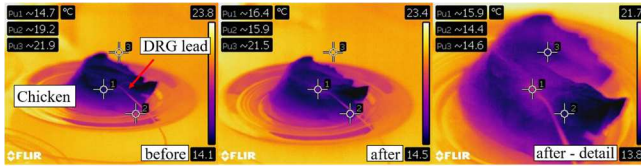

Fig. 6. Temperature change measured at the DRG lead in a chicken tissue phantom model, before and after 30 minutes of continuous stimulation (pulse characteristics: amplitude of 25.4mA, pulse width of 1280 μ s, frequency of 350Hz).

frequency of 350Hz and a pulse width of 1280 μ s. The results of the thermal measurements are presented in Fig. 6, demonstrating no significant changes in the temperature at the lead. The temperature rose from 14.7°C to 16.4°C, with the temperature at the tissue area directly surrounding the lead being at 15.9°C, overall remaining under the 2°C-increase limit suggested by the FDA. It should, however, be noted that these measurements were performed *ex vivo* in an environment with uncontrolled air flow and humidity, hence are not fully representative of an *in vivo* scenario.

C. Submission for approval

Prior to its inclusion in any clinical trial, a medical device has to be evaluated and approved by the responsible local Ethics Committee. In this case, the final design of the prototype system needs to be approved by the Erasmus Medical Centre Medical Ethics Review Committee (METC). For that purpose, the Investigational Medical Device Dossier (IMDD), a protocol containing all information on a non-CE-marked device intended to be used in clinical trials, needs to be provided. According to the CCMO-website (the Dutch Central Committee on Research Involving Human Subjects) (www.ccmo.nl), this IMDD is based on Annex II (technical documentation) of the EU Medical Device Regulation (EU nr 2017/745). Amongst the requested information for the IMDD, researchers must provide an extensive device description (including design and manufacturing when relevant), a risk analysis, an Essential Requirements Checklist including the requirements for safety and performance of the device, and evidence of conformity to all other general requirements such as biocompatibility, sterility, etc. when applicable.

IV CONCLUSION

A prototype system developed for use in clinical research on DRG stimulation for locomotion control was presented in this paper. The system allows for a very versatile experimental protocol, and features the largest number of independent stimulation channels and the largest current amplitude among previously reported systems for clinical use in locomotion applications. The characteristics of the system were tailored to ensure its suitability for use in an early clinical trial, hence emphasis was placed on safety and avoidance of infection risks. The development process and design considerations for the presented stimulator prototype, being a device interfacing (indirectly) with neuronal tissue, can serve as a guide for similar attempts. Its reproducibility, along with the introduced list of safety considerations, might facilitate an application in related experimental settings. The stimulator, together with the relevant documentation for an approval by the Ethics Committee, will be submitted at the METC.

REFERENCES

- [1] R. Osterthun *et al.*, "Functional independence of persons with long-standing motor complete spinal cord injury in the Netherlands," *J Spinal Cord Med*, May 2020, vol. 43, issue 3, pp. 380–387, E-pub August 2018.
- [2] S. Geyh *et al.*, "Quality of life after spinal cord injury: a comparison across six countries," *Spinal Cord*, April 2013, vol. 51, pp. 322–326, E-pub October 2012.
- [3] G. Courtine, M.V. Sofroniew, "Spinal cord repair: advances in biology and technology," *Nature Med*, vol. 25, pp. 898–908, June 2019.
- [4] M. L. Gill *et al.*, "Neuromodulation of lumbosacral spinal networks enables independent stepping after complete paraplegia," *Nature Med*, vol. 24, pp. 1677–1682, October 2018.
- [5] F. B. Wagner *et al.*, "Targeted neurotechnology restores walking in humans with spinal cord injury," *Nature*, vol. 563, pp. 65–71, October 2018.
- [6] C. A. Angeli *et al.*, "Recovery of Over-Ground Walking after Chronic Motor Complete Spinal Cord Injury," *N. Engl. J. Med.*, vol. 379, pp. 1244–1250, September 2018.
- [7] S. Soloukey *et al.*, "The Dorsal Root Ganglion as a Novel Neuromodulatory Target to Evoke Strong and Reproducible Motor Responses in Chronic Motor Complete Spinal Cord Injury: A Case Series of Five Patients," *Neuromodulation*, E-pub ahead of print, July 2020.
- [8] M. F. Esposito *et al.*, "Unique Characteristics of the Dorsal Root Ganglion as a Target for Neuromodulation," *Pain Med.*, vol. 20, pp. 23–30, June 2019.
- [9] S. Soloukey *et al.*, "Bilateral L2 dorsal root ganglion-stimulation suppresses lower limb spasticity following chronic motor complete Spinal Cord Injury: A case report," *Brain Stimulation*, vol. 13, issue 3, pp. 637–639, May 2020.
- [10] S. Soloukey, J.D. de Rooij, J. Drenthen, C.I. De Zeeuw, F.J.P.M. Huygen, and B.S. Harhangi, "Unilateral L2-Level DRG-stimulation evokes bilateral CPG-Like motor response in a patient with chronic pain," *Brain Stim.*, vol. 13, issue 6, pp. 1719–1721, November 2020.
- [11] V. Giagka, C. Eder, N. Donaldson, and A. Demosthenous, "An Implantable Versatile Electro-Driving ASIC for Chronic Epidural Stimulation in Rats," *IEEE Trans. Biomed. Circ. Sys.*, vol. 9, no. 3, pp. 387–400, June 2015.
- [12] G. E. Ólafsdóttir, W. A. Serdijn, and V. Giagka, "An energy-efficient, inexpensive, spinal cord stimulator with adaptive voltage compliance for freely moving rats," *Proc. 40th Int. Conf. of the IEEE Engineering in Medicine and Biology (EMBC)*, pp. 2937 – 2940, July 2018.
- [13] Y.K. Lo *et al.*, "A Fully Integrated Wireless SoC for Motor Function Recovery After Spinal Cord Injury," *IEEE Trans. Biomed. Circ. Sys.*, vol. 11, no. 3, pp. 497–509, June 2017.
- [14] V. Giagka, A. Demosthenous, and N. Donaldson, "Flexible active electrode arrays with ASICs that fit inside the rat's spinal canal," *Biomed. Microdev.*, vol. 17, no. 6, pp. 106 – 118, Dec. 2015. doi: 10.1007/s10544-015-0011-5.
- [15] Cirtec Medical, "CSI040, 16-Channel High Voltage Programmable Current Sink/Source", CSI040 NeuroStim ASSP Datasheet, Rev 1.0, April 2019.
- [16] Cirtec Medical, "CSI062 Demo Board Specification", IC Evaluation Board for CSI040, Rev. 2.0, October 2018.
- [17] K. W. King *et al.*, "DRG microstimulation evokes postural responses in awake, standing felines," *Journal of Neural Engineering*, vol. 17, no. 1, December 2019.
- [18] Boston Scientific, "Precision Spectra™ Spinal Cord Stimulator System," Directions for Use, 91057051-01 Rev A.
- [19] N.d.N. Donaldson, P.E.K. Donaldson, "When are actively balanced biphasic ('Lilly') stimulating pulses necessary in a neurological prosthesis? I Historical background; Pt resting potential; Q studies," *Med. Biol. Eng. Comput.*, vol. 24, pp. 41–49, January 1986.
- [20] K. Sooksood, T. Stieglitz and M. Ortmanns, "An Active Approach for Charge Balancing in Functional Electrical Stimulation," *IEEE Trans. Biomed. Circ. Sys.*, vol. 4, no. 3, pp. 162–170, June 2010.
- [21] S. F. Cogan, K. A. Ludwig, C. G. Welle and P. Takmakov, "Tissue damage thresholds during therapeutic electrical stimulation," *Journal of Neural Engineering*, vol. 13, no. 2, April 2016.